



VKD SERIES BALL VALVES

Data Sheet



introduction

< STANDARDS >



ASTM D1784
ASTM D2464
ASTM D2466
ASTM D2467
ASTM D4101
ASTM F437
ASTM F439
ASTM F1498



ISO 11922-1



IPEX VKD Series Ball Valves offer a variety of advanced features such as the patented seat stop carrier, a high quality stem and ball support system, and a multifunctional locking handle. The new DUAL BLOCK® system locks the union nuts preventing back-off due to vibration or thermal cycling. Deep grooves, thick o-rings, and cushioned Teflon® seats contribute to strong seals at pressures up to 232 PSI while an integral mounting flange and support bracketing combine for simple adaptation for actuation and anchoring. VKD Series Ball Valves are part of our complete systems of pipe, valves, and fittings, engineered and manufactured to our strict quality, performance, and dimensional standards.

Valve Availability

Body Material:	PVC, CPVC, PP, ABS
Size Range:	1/2" through 4"
Pressure:	232 PSI, 150 PSI (PP)
Seats:	Teflon® (PTFE)
Seals:	EPDM or Viton® (FPM)
End Connections:	Socket (IPS), Threaded (FNPT) Socket (Metric)

Sample Specification



1.0 Ball Valves - VKD

1.1 Material

- The valve body, stem, ball and unions shall be made of PVC compound which shall meet or exceed the requirements of cell classification 12454 according to ASTM D1784.
- or The valve body, stem, ball and unions shall be made of Corzan® CPVC compound which shall meet or exceed the requirements of 23447 according to ASTM D1784.
- or The valve body, stem, ball and unions shall be made of stabilized PP homopolymer compound, also containing a RAL 7032 pigment, which shall meet or exceed the requirements of Type I Polypropylene according to ASTM D4101.
- These compounds shall be listed with NSF to Standard 61 for potable water.

1.2 Seats

- The ball seats shall be made of Teflon® (PTFE) which shall be listed with NSF to Standard 61 for potable water.

1.3 Seals

- The o-ring seals shall be made of EPDM which shall be listed with NSF to Standard 61 for potable water.
- or The o-ring seals shall be made of Viton® (FPM) which shall be listed with NSF to Standard 61 for potable water.

- 1.4 All other wetted and non-wetted parts of the valves shall be listed with NSF to Standard 61 for potable water.

2.0 Connections

2.1 Socket style

- The IPS socket PVC end connectors shall conform to the dimensional standards ASTM D2466 and ASTM D2467.
- or The IPS socket CPVC end connectors shall conform to the dimensional standard ASTM F439.
- or The Metric socket PP end connectors shall conform to the dimensional standard ISO 11922-1.

2.2 Threaded style

- The female NPT threaded PVC end connectors shall conform to the dimensional standards ASTM D2464, ASTM F1498, and ANSI B1.20.1.
- or The female NPT threaded CPVC end connectors shall conform to the dimensional standards ASTM F437, ASTM F1498, and ANSI B1.20.1.
- or The female NPT threaded PP end connectors shall conform to the dimensional standards ASTM F1498, and ANSI B1.20.1.

Sample Specification (cont'd)



3.0 Design Features

- The valve shall be double blocking with union ends.
- All valves shall be full port.
- All valves shall allow for bi-directional flow.
- The valve body shall be single end entry with a threaded carrier (ball seat support).
- The threaded carrier shall be adjustable with the valve installed.
- The valve body shall have an expansion and contraction compensating groove on the molded end.
- The valve body, union nuts, and carrier shall have deep square style threads for increased strength.
- The ball and stem shall be machined smooth to minimize wear on valve seats and seals.
- All valve seats shall have o-ring backing cushions to compensate for wear and prevent seizure of the ball.
- The stem design shall feature double o-ring seals as well as a safety shear point above the o-rings.
- All valves shall have integrally molded mounting features for actuation.
- All valves shall have integrally molded support bracketing for anchoring.
- The 2-1/2" to 4" valve handle shall incorporate a transparent PVC plug and tag holder for valve identification.

3.1 Pressure Tested

- All valves shall have been pressure tested in both the open and closed positions by the manufacturer.

3.2 Pressure Rating

- All PVC and CPVC valves shall be rated at 232 PSI at 73°F.
- All PP valves shall be rated at 150 PSI at 73°F.

3.3 Markings

- All valves shall be marked to indicate size, material designation, and manufacturers name or trade mark.

3.4 Color Coding

- All PVC valves shall be color-coded dark gray.
- or All CPVC valves shall be color-coded light gray.
- or All PP valves shall be color-coded beige gray.

4.0 All valves shall be Xirtec® 140, Corzan®, or PP by IPEX or approved equal.

Technical Data

dimensions

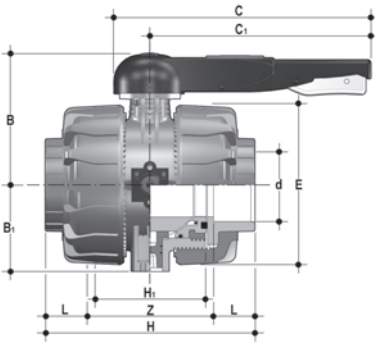
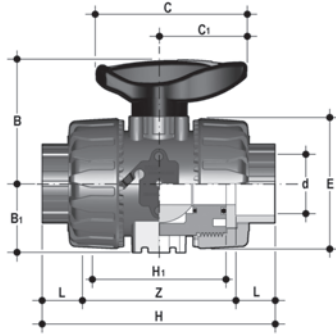

IPS socket connections

Dimension (inches)

Size	d	H	L	Z	H ₁	E	B ₁	B	C ₁	C
3/8	0.68	4.61	0.77	3.07	2.56	2.13	1.14	2.13	1.57	2.64
1/2	0.84	4.61	0.89	2.83	2.56	2.13	1.14	2.13	1.57	2.64
3/4	1.05	5.08	1.00	3.07	2.76	2.56	1.36	2.56	1.93	3.35
1	1.32	5.59	1.13	3.33	3.07	2.87	1.54	2.74	1.93	3.35
1-1/4	1.66	6.38	1.26	3.86	3.46	3.39	1.81	3.25	2.52	4.25
1-1/2	1.90	6.77	1.38	4.02	3.66	3.86	2.05	3.50	2.52	4.25
2	2.38	7.83	1.50	4.83	4.37	4.80	2.44	4.25	2.99	5.28
2-1/2	2.88	9.25	1.75	5.75	5.24	6.46	3.43	6.46	6.89	8.86
3	3.50	10.63	1.89	6.85	5.87	7.99	4.13	6.97	10.71	12.87
4	4.50	12.13	2.26	7.60	6.57	9.37	5.08	7.68	12.99	15.16

female NPT threaded connections

Dimension (inches)

Size	R	H	L	Z	H ₁	E	B ₁	B	C ₁	C
3/8	3/8-UPT	4.06	0.54	2.98	2.56	2.13	1.14	2.13	1.57	2.69
1/2	1/2-NPT	4.37	0.70	2.97	2.56	2.13	1.14	2.13	1.57	2.64
3/4	3/4-NPT	4.61	0.71	3.19	2.76	2.56	1.36	2.56	1.93	3.35
1	1-NPT	5.31	0.89	3.54	3.07	2.87	1.54	2.74	1.93	3.35
1-1/4	1-1/4-NPT	6.02	0.99	4.05	3.46	3.39	1.81	3.25	2.52	4.25
1-1/2	1-1/2-NPT	6.14	0.97	4.20	3.66	3.86	2.05	3.50	2.52	4.25
2	2-NPT	7.32	1.17	4.99	4.37	4.80	2.44	4.25	2.99	5.28
2-1/2	2-1/2-NPT	9.25	1.31	6.64	5.24	6.46	3.43	6.46	6.89	8.86
3	3-NPT	10.63	1.40	7.83	5.87	7.99	4.13	6.97	10.71	12.87
4	4-NPT	12.13	1.48	9.17	6.57	9.37	5.08	7.68	12.99	15.16

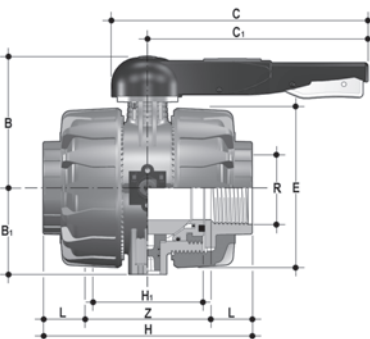
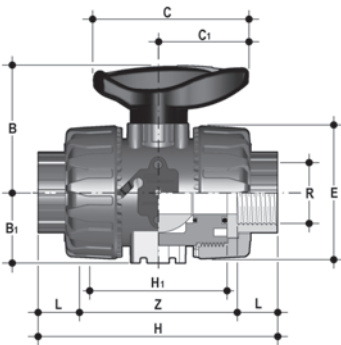

Technical Data (cont'd)

VKD Flanged Connections

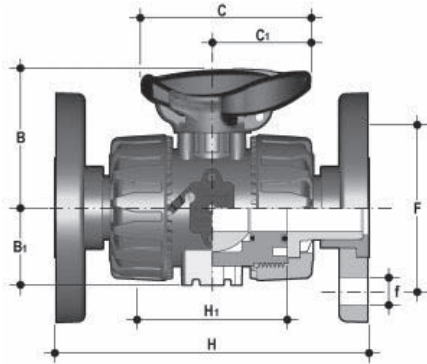

Dimension (inches)

Size	H	H1	B	B1	C	C1	F	f	U
1/2"	5.63	2.56	2.13	1.14	2.64	1.58	2.37	0.63	0.16
3/4"	6.77	2.76	2.56	1.36	3.35	1.93	2.75	0.63	0.16
1"	7.36	3.07	2.74	1.54	3.35	1.93	3.13	0.63	0.16
1 1/4"	7.48	3.47	3.25	1.81	4.25	2.52	3.5	0.63	0.16
1 1/2"	8.35	3.66	3.5	2.05	4.25	2.52	3.87	0.63	0.16
2"	9.21	4.37	4.25	2.44	5.28	2.99	4.75	0.75	0.16

Note: Dimensions based on VKD ANSI 150 Flanging Kit

metric socket connections

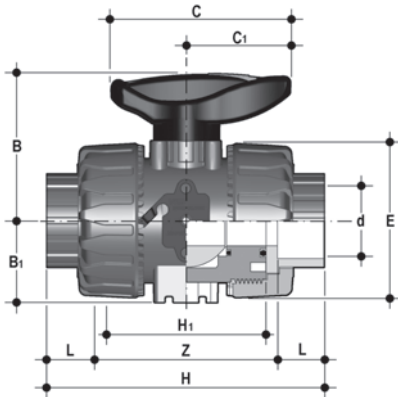

Dimension (inches)

Size	d	H	L	Z	H1	E	B1	B	C1	C
20mm	0.79	4.02	0.57	2.87	2.56	2.13	1.14	2.13	1.57	2.64
25mm	0.98	4.49	0.63	3.23	2.76	2.56	1.36	2.56	1.93	3.35
32mm	1.26	4.96	0.71	3.54	3.07	2.87	1.54	2.74	1.93	3.35
40mm	1.57	5.55	0.81	3.94	3.35	3.39	1.81	3.25	2.52	4.25
50mm	1.97	6.46	0.93	4.61	3.66	3.86	2.05	3.50	2.52	4.25
63mm	2.48	7.83	1.08	5.67	4.37	4.80	2.44	4.25	2.99	5.28

support bracket

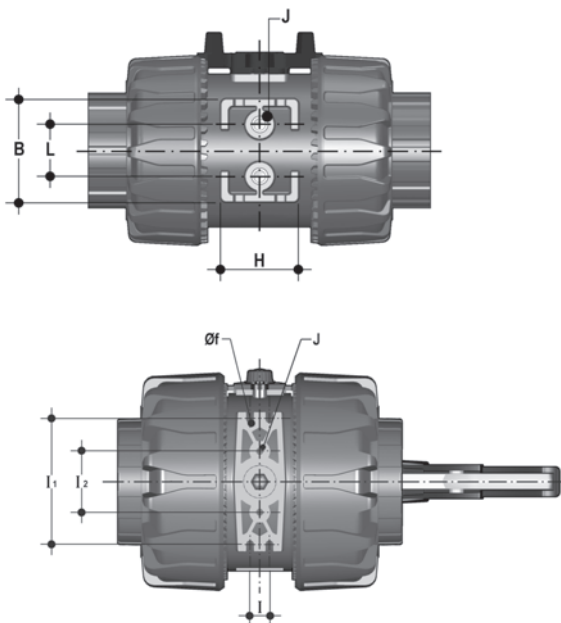

Dimension (inches)

Size	J	B	L	H
1/2	M4	1.24	0.79	1.06
3/4	M4	1.57	0.79	1.18
1	M4	1.57	0.79	1.18
1-1/4	M6	1.97	1.18	1.38
1-1/2	M6	1.97	1.18	1.38
2	M6	2.36	1.18	1.57

Dimension (inches)

Size	J	f	I	I1	I2
2-1/2	M6	0.25	0.69	3.54	2.04
3	M8	0.33	0.83	4.43	2.48
4	M8	0.33	0.83	5.39	2.64

Technical Data (cont'd)

actuation pad

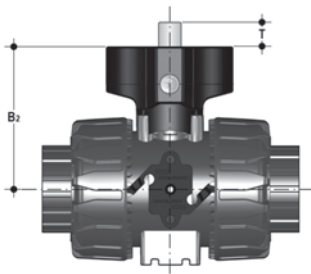
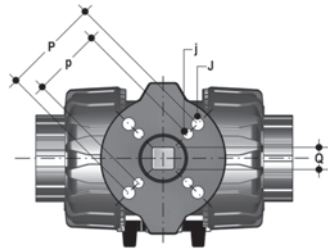

Dimension (inches)

Size	B ₂	p	P	j	J	T	Q
1/2	2.28	F03	F04	0.22	0.22	0.47	0.43
3/4	2.89	F03	F05	0.22	0.26	0.47	0.43
*3/4	2.89	F04		0.22		0.47	0.43
1	2.91	F03	F05	0.22	0.26	0.47	0.43
*1	2.91	F04		0.22		0.43	0.43
1-1/4	3.82	F05	F07	0.26	0.33	0.63	0.55
1-1/2	4.09	F05	F07	0.26	0.33	0.63	0.55
2	4.49	F05	F07	0.26	0.33	0.63	0.55

*Available upon request.

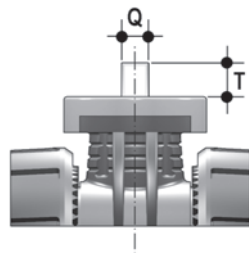
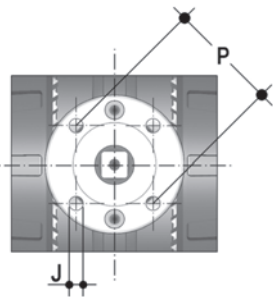

Dimension (inches)

Size	P	J	T	Q
2-1/2	F07	0.35	0.63	0.55
3	F07	0.35	0.63	0.55
4	F07	0.35	0.75	0.67

weights

Approximate Weight (lbs)

Size (inches)		IPS / Metric Socket			FNPT Threaded		
IPS	Metric	PVC	CPVC	PP	PVC	CPVC	PP
1/2	20mm	0.47	0.51	0.32	0.46	0.50	0.31
3/4	25mm	0.76	0.82	0.48	0.74	0.79	0.50
1	32mm	0.99	1.06	0.66	0.99	1.06	0.67
1-1/4	40mm	1.58	1.70	1.06	1.49	1.61	1.01
1-1/2	50mm	2.15	2.31	1.50	2.11	2.26	1.43
2	63mm	3.77	4.06	2.57	3.68	3.95	2.50
2-1/2	-	9.68	10.5	-	9.69	10.5	-
3	-	15.9	17.3	-	16.0	17.4	-
4	-	24.4	26.9	-	24.5	27.0	-

Technical Data (cont'd)

pressure – temperature ratings

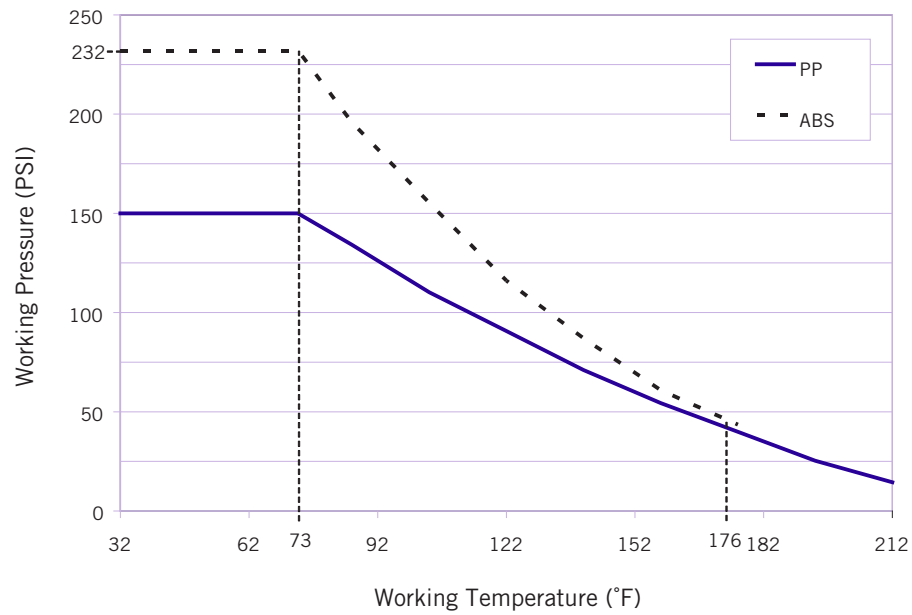
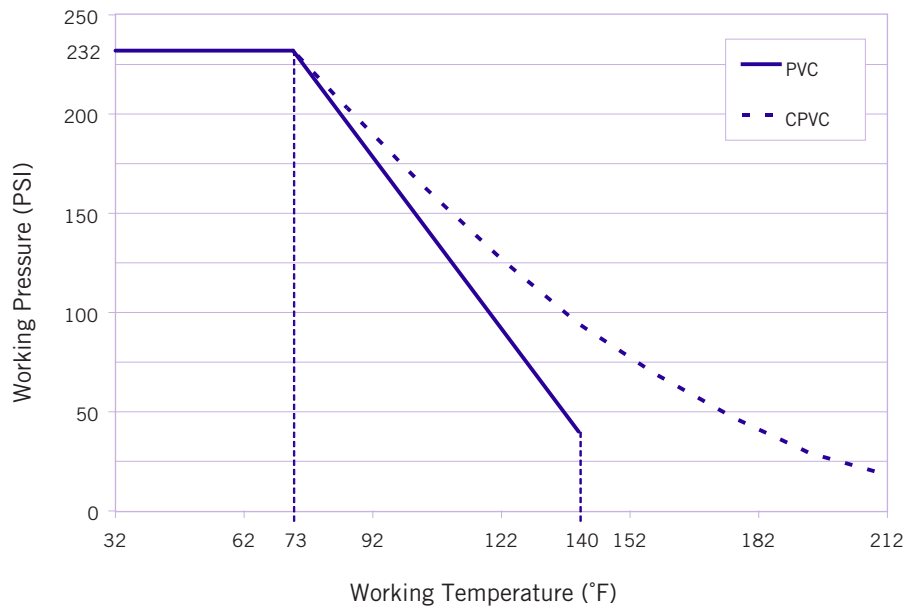

Technical Data (cont'd)

flow coefficients



The flow coefficient (C_v) represents the flow rate in gallons per minute (GPM) at 68°F for which there is a 1 PSI pressure drop across the valve in the fully open position. These values are determined from an industry standard testing procedure which uses water as the flowing media (specific gravity of 1.0). To determine specific flow rate and pressure loss scenarios, one can use the following formula:

$$f = sg \times \left(\frac{Q}{C_v} \right)^2$$

Where,

- f is the pressure drop (friction loss) in PSI,
- sg is the specific gravity of the fluid,
- Q is the flow rate in GPM,
- C_v is the flow coefficient.

Size (in)	C_v
1/2	14.0
3/4	27.0
1	53.9
1-1/4	77.0
1-1/2	123
2	238
2-1/2	368
3	497
4	665

pressure loss chart

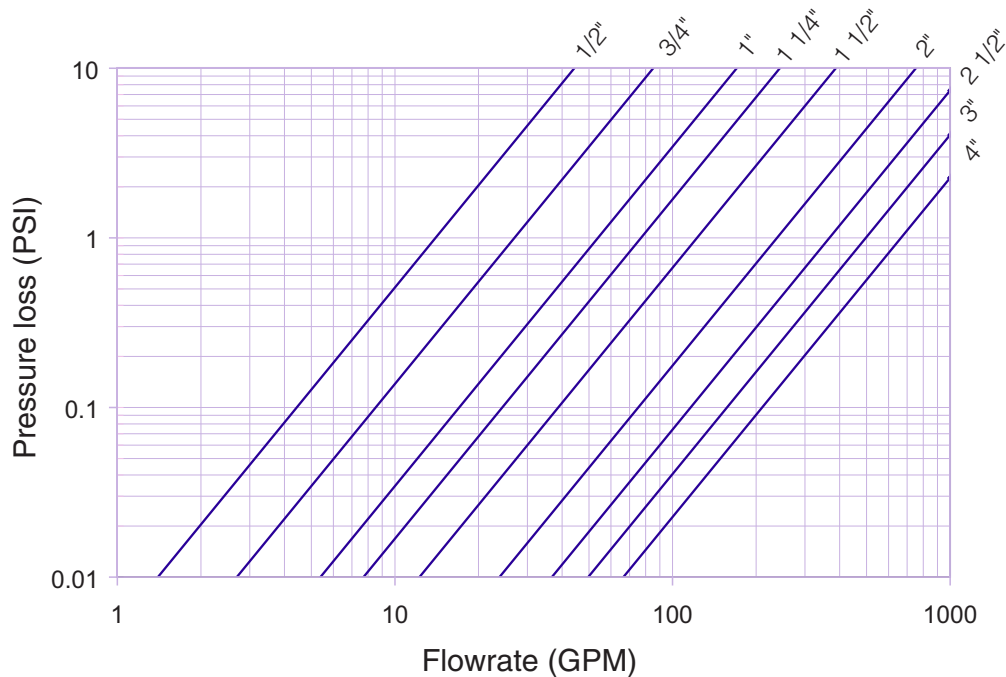

Customize VKD EasyFit

sizes 2-1/2" to 4"



- A** Transparent PVC Service Plug
- B** PVC Tag Holder
- C** EasyFit Multifunction Handle

It is often necessary to customize a valve by labelling or tagging it in order to mark, protect and identify it.



The 2-1/2" to 4" VKD is equipped with a specially designed water resistant module for the customization of the valve. The module is housed in the handle and is composed of a transparent PVC service plug and a white tag holder. The transparent plug can be easily removed to be used for self-labelling on its blank side. Self labelling can be done in several ways, but we recommend designing and printing custom labels through the EasyFit Labelling System (LSE).

Components

sizes 1/2" to 2"

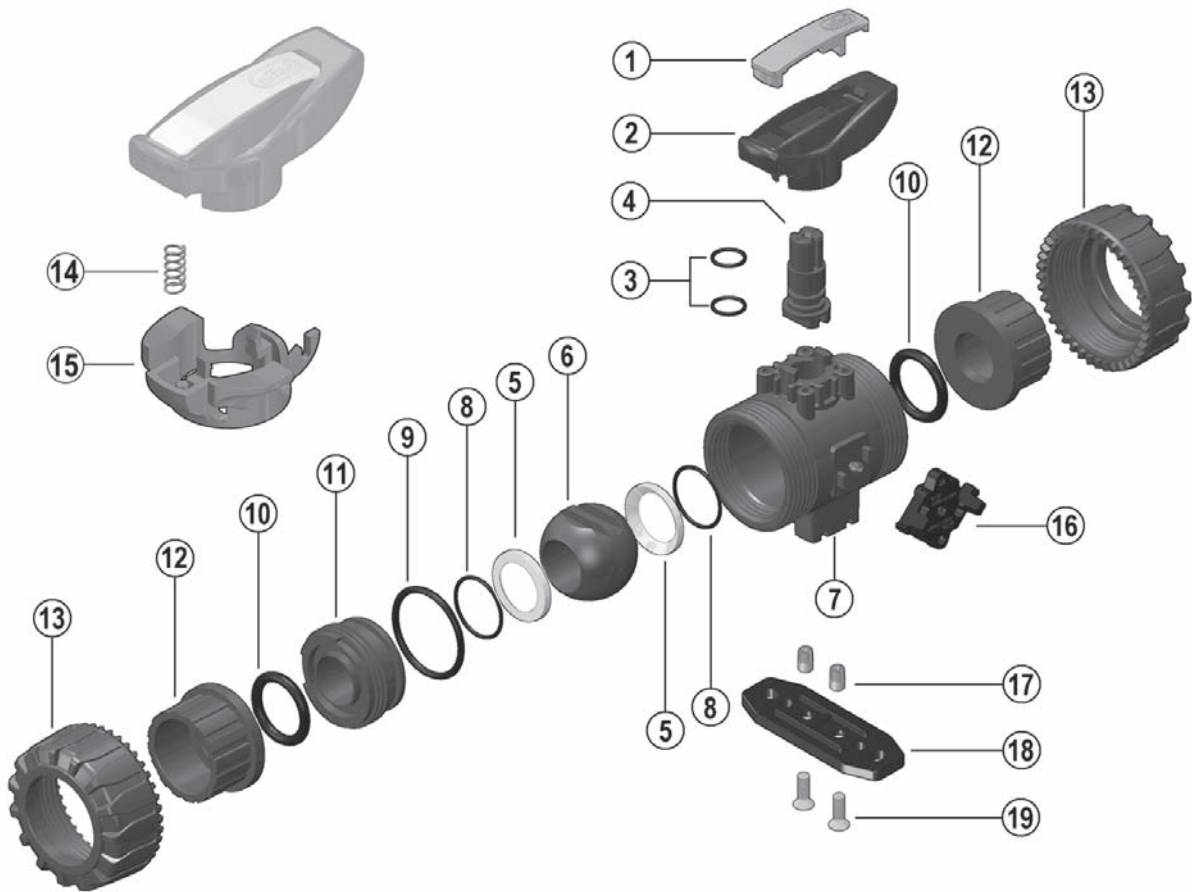

#	Component	Material	Qty
1	insert	PVC / CPVC / PP	1
2	handle	PVC / CPVC / PP	1
3	stem o-ring	EPDM / Viton®	2
4	stem	PVC / CPVC / PP	1
5	ball seat	PTFE	2
6	ball	PVC / CPVC / PP	1
7	body	PVC / CPVC / PP	1
8	ball seat o-ring	EPDM / Viton®	2
9	body o-ring	EPDM / Viton®	1
10	socket o-ring	EPDM / Viton®	2

#	Component	Material	Qty
11	carrier with stop ring	PVC / CPVC / PP	1
12	end connector	PVC / CPVC / PP	2
13	union nut	PVC / CPVC / PP	2
14*	spring	SS	1
15*	handle lock	GRPP	1
16	DUAL BLOCK®	POM	1
17*	bracket bushing	SS / brass	2
18*	mounting plate	GRPP	1
19*	screw	SS	2

* Optional Accessories

Components (cont'd)

sizes 2-1/2" to 4"

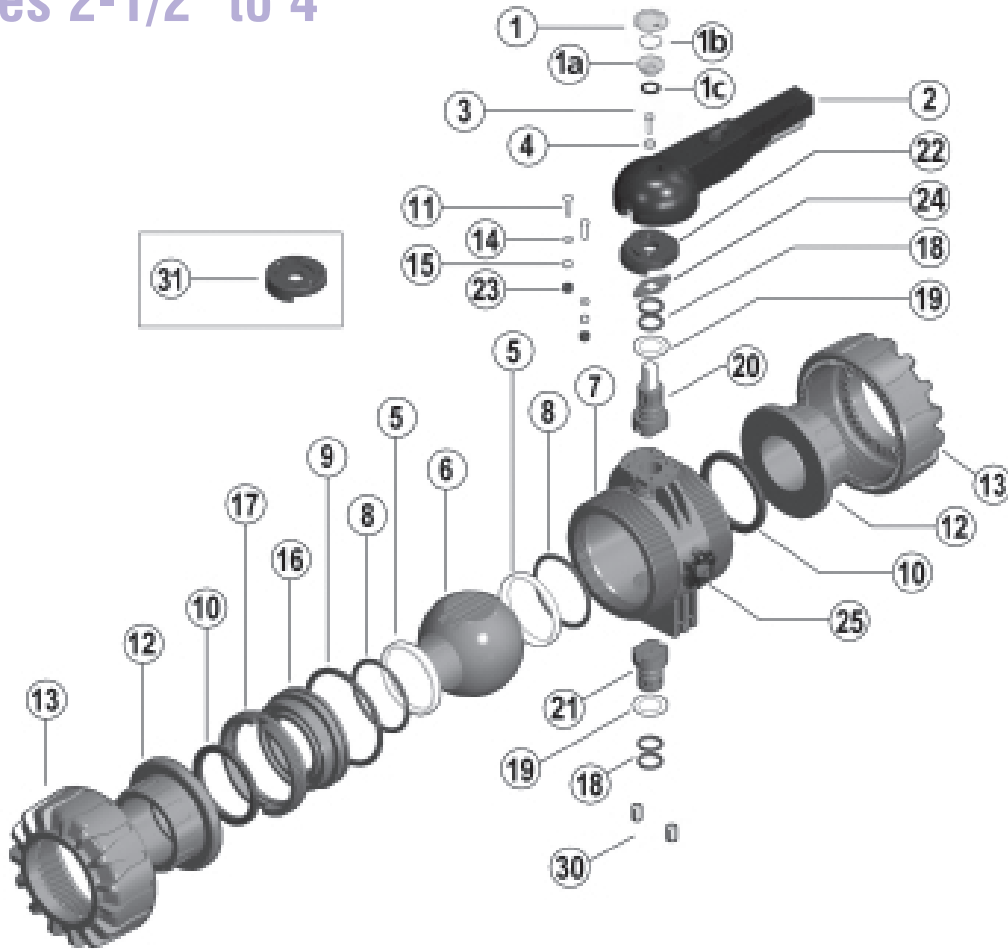

#	Component	Material	Qty
1 a,b,c	transparent service plug	PE	1
2	handle	PVC	1
3	bolt	SS	1
4	washer	SS	1
5	ball seat	PTFE	2
6	ball	PVC / CPVC	1
7	body	PVC / CPVC	1
8	ball seat o-ring	EPDM / Viton®	2
9	body o-ring	EPDM / Viton®	1
10	socket seal	EPDM / Viton®	2
11	bolt	SS	2
12	end connector	PVC / CPVC	2
13	union nut	PVC / CPVC	2
14	washer	SS	2
15	nut	SS	2
16	carrier	PVC / CPVC	1

#	Component	Material	Qty
17	stop ring	PVC / CPVC	1
18	stem o-ring	EPDM / Viton®	4
19	bushing	PTFE	2
20	upper stem	PVC / CPVC & SS	1
21	lower stem	PVC / CPVC	1
22	pad	GRPP	1
23	protective cap	PE	2
24	spring	SS	2
25	nut block	GRPP	2
26	cover	PP	1
27	nut block button	GRPP	1
28	protective cap	PE	1
29	screw	nylon	2
30	bracket bushing	brass	2
31	actuation pad	GRPP	1

Installation Procedures

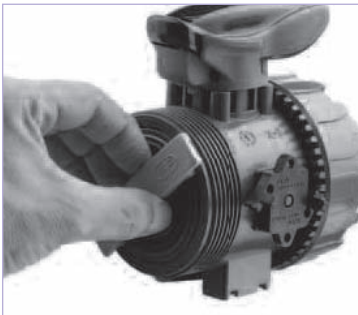

1. Remove the union nuts (part #13 on previous pages) and slide them onto the pipe.
2. Please refer to the appropriate connection style sub-section:
 - a. For socket style, solvent cement or fuse the end connectors (12) onto the pipe ends. For correct solvent cementing procedure, please refer to the section entitled, "Joining Methods – Solvent Cementing" in the IPEX Industrial Technical Manual Series, "Volume I: Vinyl Process Piping Systems". **Be sure to allow sufficient cure time before continuing with the valve installation.**
 - b. For threaded style, thread the end connectors (12) onto the pipe ends. For correct joining procedure, please refer to the section entitled, "Joining Methods – Threading" in the IPEX Industrial Technical Manual Series, "Volume I: Vinyl Process Piping Systems".
3. Open and close the valve to ensure that the carrier (11 or 16) is at the desired adjustment. If adjustment is required, ensure that the valve is in the closed position then remove the insert tool (1) from the handle (2). For sizes 2-1/2" to 4", use the tool that accompanies the valve. Line up the moldings on the tool with the slots in the carrier. Tighten or loosen to the desired position then replace the tool on the handle.
4. Ensure that the valve is in the closed position, and that the socket o-rings (10) are properly fitted in their grooves. If anchoring is required, insert the bracket bushings (17) into the bottom of the valve (sizes 1/2" to 2" only). Carefully place the valve in the system between the two end connections and fix if necessary.
5. Tighten the union nut on the side opposite to that which is marked "ADJUST". Hand tightening is typically sufficient to maintain a seal for the maximum working pressure. **Over-tightening may damage the threads on the valve body and/or the union nut, and may even cause the union nut to crack.**

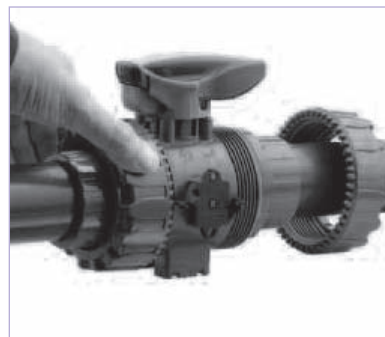

Installation Procedures (cont'd)

Size 1/2" - 2"

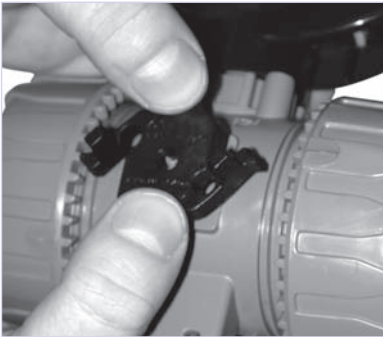

6. Tighten the union nut on the side marked "ADJUST". Tightening the union nuts in this order results in the best possible valve performance due to optimum positioning and sealing of the ball and seat support system.
7. Open and close the valve to again ensure that the cycling performance is adequate. If adjustment is required, place the valve in the closed position, loosen the union nuts, remove the valve from the system, and then continue from Step 3.
8. Engage the Dual Block[®] system by affixing the molded piece (16, sizes 1/2" to 2") to the side of the valve body or by turning the red knob (27, sizes 2-1/2" to 4") to the locked position. This feature will prevent back-off of the union nuts during operation.

Size 2-1/2" - 4"

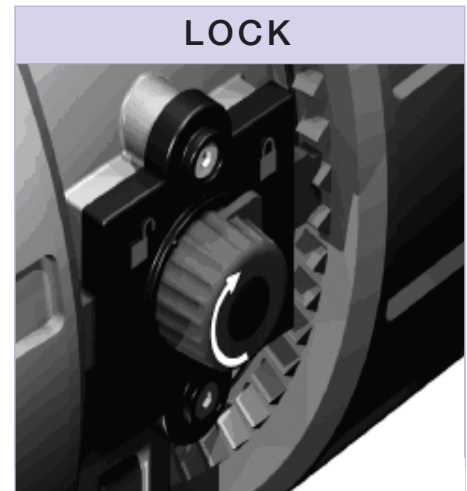
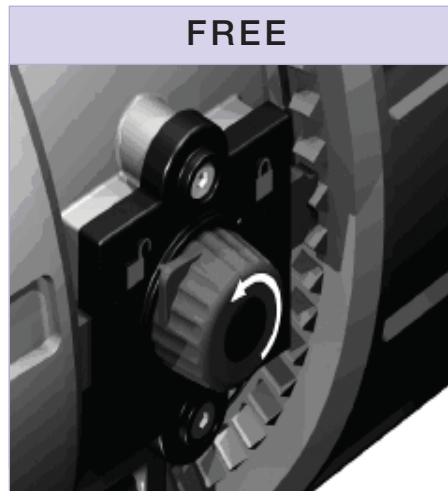

Valve Maintenance

disassembly



1. If removing the valve from an operating system, isolate the valve from the rest of the line. **Be sure to depressurize and drain the valve and isolated branch.**
2. If necessary, detach the valve from the support structure by disassembling the connections to the optional bracket on the bottom of the valve body (7).
3. Unlock the Dual Block® system by compressing the two ends of the molded piece (16, sizes 1/2" to 2") or by turning the red knob (27, sizes 2-1/2" to 4") to the unlocked position. Loosen both union nuts (13) and drop the valve out of the line. If retaining the socket o-rings (10), take care that they are not lost when removing the valve from the line.
4. Place the valve in the open position then line up the moldings on the wrench tool (1, sizes 1/2" to 2") with the slots in the carrier (found on the side marked "ADJUST"). Loosen and remove the carrier (11 or 16).
5. Carefully press the ball (6) out of the valve body, taking care not to score or damage the outer surface.
6. Remove the handle (2) by pulling upwards (sizes 1/2" to 2") or by removing transparent service plug (1 a,b,c), bolt (3) and washer (4) (sizes 2-1/2" to 4").
7. On sizes 2-1/2" to 4", remove the throttling pad (22) by loosening and removing the bolts (11), washers (14), nuts (15), and caps (23).
8. Press the stem (4 or 20) into the valve body from above. On sizes 2-1/2" to 4", remove the lower stem (21) by pushing it into the valve body from below.
9. The stem o-rings (3 or 18), body o-ring (9), ball seats (5), ball seat o-rings (8), and bushings (19, sizes 2-1/2" to 4") can now be removed and/or replaced.

Note: It is not typically necessary to disassemble the Dual Block® components.

assembly



Note: Before assembling the valve components, it is advisable to lubricate the o-rings with a water soluble lubricant. **Be sure to consult the "IPEX Chemical Resistance Guide" and/or other trusted resources to determine specific lubricant-rubber compatibilities.**

1. Replace the stem o-rings (3 or 18), body o-ring (9), ball seat o-rings (8), ball seats (5), and bushings (19, sizes 2-1/2" to 4") in their proper positions.
2. Insert the stem (4 or 20) into position from inside the valve body (7). On sizes 2-1/2" to 4", insert the lower stem (21) as well.
3. On sizes 2-1/2" to 4", replace the throttling pad (22) and affix in position using the bolts (11), washers (14), and nuts (15). Replace the caps (23) over the nuts.
4. Replace the handle (2). On sizes 2-1/2" to 4", affix using the bolt (3) and washer (4), then replace the transparent service plug (1 a,b,c).
5. Carefully insert the ball (6) into the valve body, taking care not to score or damage the outer surface. Ensure that the valve handle and ball position correspond to the same operating position.
6. Insert the threaded carrier (11 or 16) and tighten into the valve body. Use the wrench tool to sufficiently tighten.
7. Place the end connectors (12) into the union nuts (13), then thread onto the valve body taking care that the socket o-rings remain properly fitted in their grooves.
8. Engage the Dual Block® system by affixing the molded piece (16, sizes 1/2" to 2") to the side of the valve body or by turning the red knob (27, sizes 2-1/2" to 4") to the locked position.

Testing and Operating

Size 2-1/2"

FREE



LOCK



Sizes 3" & 4"

FREE

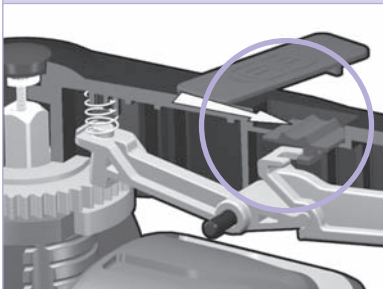

LOCK

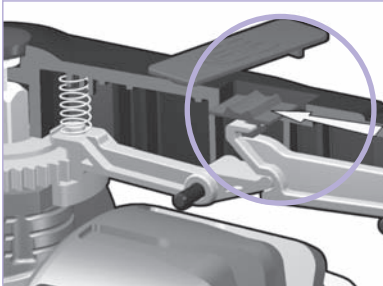

The purpose of system testing is to assess the quality of all joints and fittings to ensure that they will withstand the design working pressure, plus a safety margin, without loss of pressure or fluid. Typically, the system will be tested and assessed in sub-sections as this allows for improved isolation and remediation of potential problems. With this in mind, the testing of a specific installed valve is achieved while carrying out a test of the overall system.

An onsite pressure test procedure is outlined in the IPEX Industrial Technical Manual Series, *"Volume I: Vinyl Process Piping Systems"* under the section entitled, *"Testing"*. The use of this procedure should be sufficient to assess the quality of a valve installation. **In any test or operating condition, it is important to never exceed the pressure rating of the lowest rated appurtenance in the system.**

Important points:

- Never test thermoplastic piping systems with compressed air or other gases including air-over-water boosters.
- When testing, do not exceed the rated maximum operating pressure of the valve.
- Avoid the rapid closure of valves to eliminate the possibility of water hammer which may cause damage to the pipeline or the valve.

For safety reasons, please contact IPEX customer service and technical support when using volatile liquids such as hydrogen peroxide (H₂O₂) and sodium hypochlorite (NaClO). These liquids may vaporize causing a potentially dangerous pressure increase in the dead space between the ball and the valve body. Special VKD ball valves are available for these types of critical applications.

Note: The VKD handle incorporates a locking mechanism that prevents unintentional rotation. When engaged, the spring-loaded handle release is locked and the valve cannot be cycled. A padlock can be installed through this portion of the handle as an additional safety precaution.

Please contact IPEX customer service and technical support with regard to any concern not addressed in this data sheet or the technical manual.

About IPEX

About the IPEX Group of Companies

As leading suppliers of thermoplastic piping systems, the IPEX Group of Companies provides our customers with some of the world's largest and most comprehensive product lines. All IPEX products are backed by more than 50 years of experience. With state-of-the-art manufacturing facilities and distribution centers across North America, we have established a reputation for product innovation, quality, end-user focus and performance.

Markets served by IPEX group products are:

- Electrical systems
- Telecommunications and utility piping systems
- PVC, CPVC, PP, ABS, PEX, FR-PVDF and PE pipe and fittings (1/4" to 48")
- Industrial process piping systems
- Municipal pressure and gravity piping systems
- Plumbing and mechanical piping systems
- PE Electrofusion systems for gas and water
- Industrial, plumbing and electrical cements
- Irrigation systems

Products manufactured by IPEX Inc. and distributed in the United States by IPEX USA LLC.

This literature is published in good faith and is believed to be reliable. However, it does not represent and/or warrant in any manner the information and suggestions contained in this brochure. Data presented is the result of laboratory tests and field experience.

A policy of ongoing product improvement is maintained. This may result in modifications of features and/or specifications without notice.

Products manufactured by IPEX Inc. and distributed in the United States by IPEX USA LLC.